



# Culligan®



REVERSE OSMOSIS

# SW EVO

SEA WATER DESALINATION. EVOLVED



# SW EVO

SEA WATER DESALINATION. EVOLVED

## SEA WATER DESALINATION.

The **SW Evo Sea Water Reverse Osmosis desalinator** from **Culligan** produces 5 to 40 m<sup>3</sup>/hr (22 and 175 GPM) of fresh water from feed waters with up to 42,000 ppm of salinity.

The **SW Evo** uses the latest energy recovery technologies that minimize operational costs, whilst the reverse osmosis membrane technology removes over **99%** of salt and other contaminants leaving only high quality water.

All units are assembled in the **Culligan** factory in Italy and are skid mounted for simple installation and easy start-up.

Thanks to an innovative modular design, **Culligan** is able to offer this high quality construction with some of the fastest delivery times on the market.

## STANDARD FEATURES

Culligan uses the highest quality system components to ensure absolute reliability.

- Corrosion resistant skid.
- High efficiency membranes suitable for Boron removal.
- High pressure pump - all wetted parts in super duplex (remainder in duplex)
- Danfoss iSave Energy Recovery installed as standard on all units except the SW Evo 04
- Variable Frequency Drive for High Pressure Pump and Energy Recovery
- High pressure pipework is in Duplex and all Low pressure piping is in u-PVC
- 1 micron pre-filtration with u-PVC housing
- Pressure monitoring instrumentation
- Digital flow meters on HPP suction, Energy Recovery suction and product

**60%**  
LOWER ENERGY

The Danfoss iSave Energy Recovery Device (ERD) can **save up to 60% of energy consumed** during the reverse osmosis process.

Typical Energy consumption after 2 years operation is less than 2.2 kWh/m<sup>3</sup>.

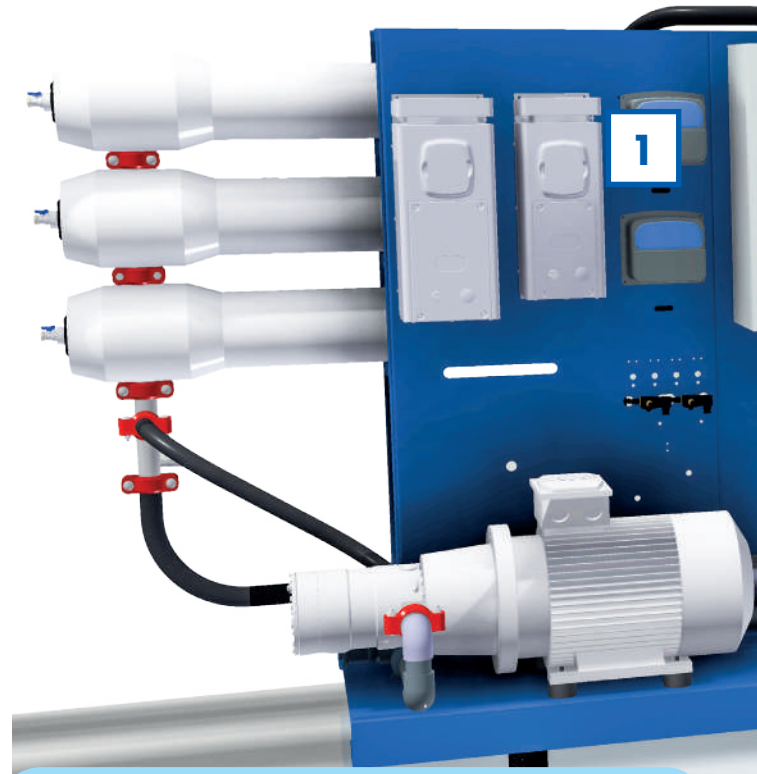

## BENEFITS INCLUDE:

- Energy efficient design reduces operating costs - approx. 2.2 kWh/m<sup>3</sup> of produced water
- Fastest Delivery Times
- Skid-mounted on one self-contained skid - no assembly, just plug and-play
- Fully configurable thanks to a complete range of upgrade options
- Worldwide technical & service support
- Made in Italy
- Fully CE compliant

# OPTIONS & UPGRADES FOR TOTAL FLEXIBILITY

A full range of upgrade options allow users to easily configure the SW Evo to meet their specific needs. All options are installed directly onto the SW Evo skid.

## AVAILABLE OPTIONS:

- 1 Advanced instrumentation options including **conductivity** and **REDOX** instrumentation.
- 2 Additional **1 and 5 micron pre-filter** cartridges. Ideal when dealing with variable feed water.
- 3 Integrated **flushing tank system**. Each time the unit shuts down or during alarm conditions the unit will flush the membranes with treated product water.



4

The flushing system can be further upgraded to provide **CIP** (Cleaning In Place) chemical cleaning.

5

**Chemical dosing stations** for Antiscalant and Bisulphite for chlorine removal.



### Culligan SW PLC control system option

- 10" touch screen display
- Controls all functions of the unit.
- Monitors all instrumentation
- Alarm notification
- Historical trending
- Ethernet/RS232/485/422/USB



In addition to the Culligan SW PLC control a wide range of alternative power and control options are also available. These include:

- **Quick connection kit** – pre-wired junction box for quick and simple integration into existing control systems
- **PLC connection pack** for connection into a pre-existing central PLC system. Includes 4-20mA pressure and flow instrumentation
- Bespoke **PLC** and **relay based** control panels are also available on request



MODEL	SW Evo 4	SW Evo 8	SW Evo 12	SW Evo 16	SW Evo 20	SW Evo 24	SW Evo 32	SW Evo 40
Nominal Flow <sup>(1)</sup> m <sup>3</sup> /h (GPM)	4 (18)	8 (35)	12 (53)	16 (70)	20 (88)	24 (105)	32 (140)	40 (175)
Membrane Quantity	6	12	18	24	30	36	48	60
Vessels x membranes	1X6	2X6	3X6	4X6	5X6	6X6	8X6	10X6
Pump power (kW) 380V ~ 50Hz-3pH	22	24	35.5	48	56	66	93.5	108.5
Piping : Low Pressure	U-PVC	U-PVC	U-PVC	U-PVC	U-PVC	U-PVC	U-PVC	U-PVC
Piping : High Pressure	Duplex	Duplex	Duplex	Duplex	Duplex	Duplex	Duplex	Duplex
Connections								
Feed	1.5"	2.5"	3"	4"	4"	4"	5"	6"
Product	1"	1.5"	2"	2"	2.5"	2.5"	3"	3"
Reject	1"	1.5"	2"	2.5"	2.5"	3"	3"	4"
Dimensions mm (inches)	A B C	6900x (272x) 1340x (53x) 2070 (81)	6900x (272x) 1340x (53x) 2070 (81)	6900x (272x) 1340x (53x) 2070 (81)	6900x (272x) 2150x (84x) 2170 (85)	6900x (272x) 2150x (84x) 2170 (85)	6900x (272x) 2200x (87x) 2190 (86)	6900x (272x) 2200x (87x) 2190 (86)

<sup>1</sup> Nominal capacity based on a 3 years old RO membranes operating at 40% recovery on a properly pre-treated feed water of 36000 ppm TDS as NaCl, 20 °C, Silt Density index (SDi) below 3, and supplying water to atmosphere

## MATERIALS OF CONSTRUCTION

Frame 4/8/12 models	Polyurethane painted galvanized steel
Frame 16/24/32/40 models	polyurethane painted welded steel including organic zinc primer.
Membrane Elements	Hydranautics SWC5 max 8"
Membrane Housing	FRP 1000 PSI
Low Pressure Pipe	u-PVC PN16
High Pressure Pipe	Duplex Stainless Steel SAF2205
Cartridge filter housing	U-PVC

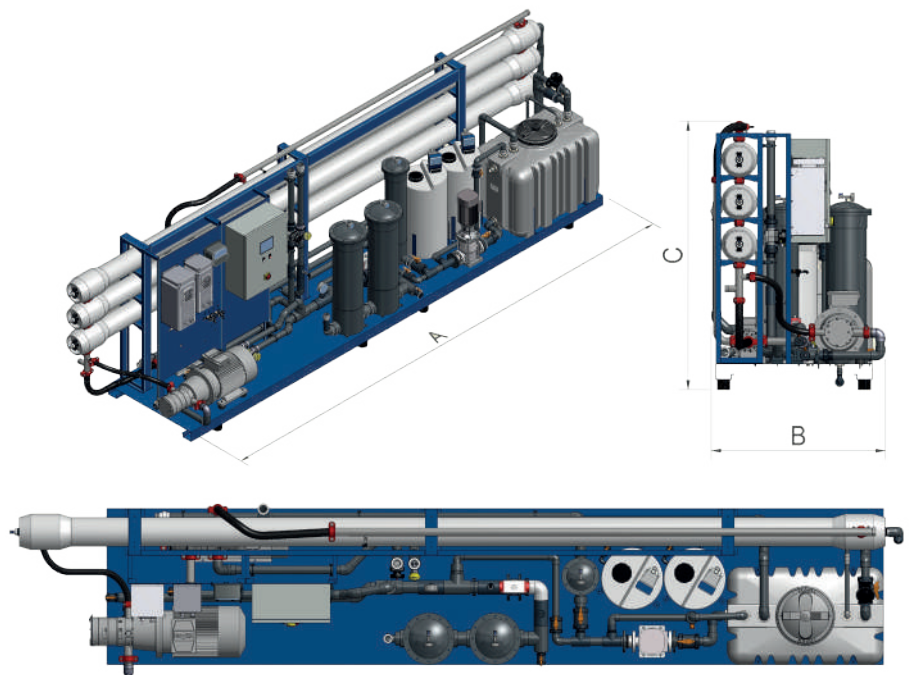

Cat.No- BU0193/04-2016



Contact your local Culligan representative for more details

Culligan reserves the right to change any technical or design specifications for the models shown in this brochure.

**Place your commercial and industrial water treatment needs in the hands of a global leader.**

For over 80 years, Culligan has made better water. Our global network, comprised of 900+ dealers and international licensees in over 90 countries, is dedicated to addressing your water-related problems. As a worldwide leader in water treatment, our sales representatives and service technicians are familiar with the local water conditions in your area. Being global and local position us to deliver customized solutions to commercial and industrial water issues that affect your business and your bottom line.